

Preparations



Protect against static discharge. Your work area must be static-safe and include a properly grounded conductive cushioned mat to hold the printer and a conductive wrist strap for yourself.

Open the printer by pulling the release latches forward, then lifting the top cover. Remove any ribbon from the carriage.

Removal

1. Grasp the print head spring ④ and pull it to the left; then, slide it free of the carriage.
2. Use the spring to pry the print head clip ③ off the right side of the carriage.
3. Pull the print head and bracket ① forward.
4. Use a #2 Phillips driver to remove the screw ② that holds the ground wire.
5. Unplug both bundles ① ② of print head wires from the left and right connectors.

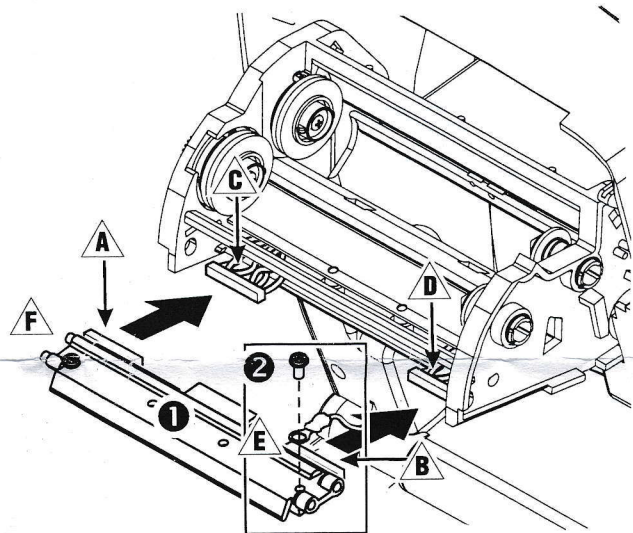

Assembly

1. Align the print head and bracket ① to plug the left ③ and right ④ connectors into the black ⑤ and white ⑥ wire bundles.
2. Attach the ground wire ⑦ and secure it with the screw ②. Use a #2 Phillips driver to tighten it.
3. Insert the bracket pegs ⑧ into the left side of the carriage.
4. Align the right side of the bracket and insert the print head clip ③ through the right side of the ribbon carriage into the bracket.

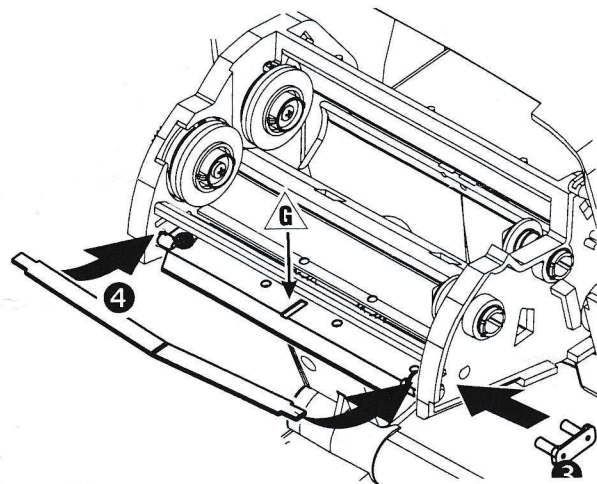

5. Slip the left end of the print head spring ④ into the left side of the ribbon carriage; then slide the right end into the other side. The angle of the "v" fits into the indent on top of the print head bracket ⑥.
6. Clean the print head with the cleaning pen.

Assembling the Printer

Reload media and ribbon. Plug in the power cord, turn on the printer and run the AutoSense routine to get a dump mode printout.